

AUTOTESTER - AUTOMATIC SEAL INTEGRITY TESTER AND CONVERGER SYSTEM



JENTON
ariana



A non-destructive leakage and gas volume tests for C.A.P, M.A.P ready meals packs etc. from a thermoformer, tray sealer or flow wrapper.

Leaking packs are rejected into a standard bin and good packs are converged into a single lane.

The JENTON-ARIANA test system subjects each pack to the longest possible test time in order to identify and reject leaking packs.

The AUTOTESTER offers:

- Unique proven Jenton-Ariana test system.
- Over-gas detection as standard.
- Colour touch screen
- Quick product change-over
- Inbuilt single lane converger.
- Long term industry tested

Available in various multi lane and row configurations, all under operators control via the colour touch-screen display ensuring minimum downtime between the various lane and row configurations.

Controlled Atmosphere Packaging (C.A.P) of fresh produce has extended the shelf-life for many perishable products. The JENTON-ARIANA Seal Tester /Converger has been developed as an effective method of detecting leaking packs at source & allowing product repacking. Sound packs are converged into a single lane for the following metal detection, check-weighing and pricing systems. Machines supplied for all lane configurations.

DIMENSIONS

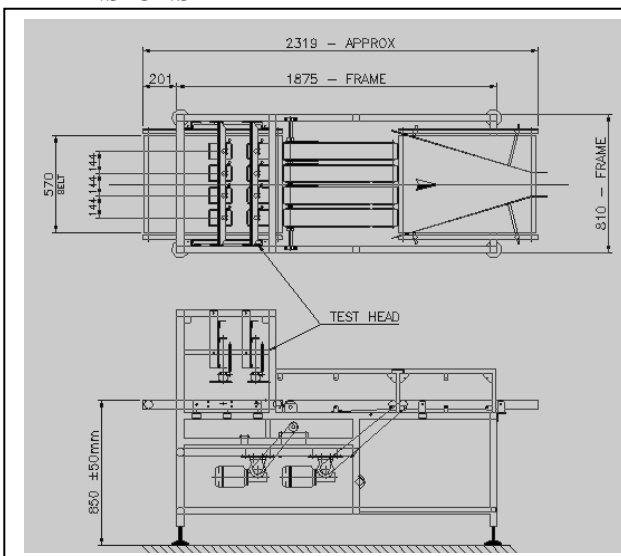

SPECIFICATIONS

Autotester	
Testing speed	Up to 20 cycles/min
Pack size range	Thickness: 5mm – 150mm Width: 30mm – 240mm Length: 30mm – 450mm
Protection	IP65
Machine weight	250kg
Power supply	AC 200-240v 50Hz 4A
Air supply	4bar 60 L/min (free air)